

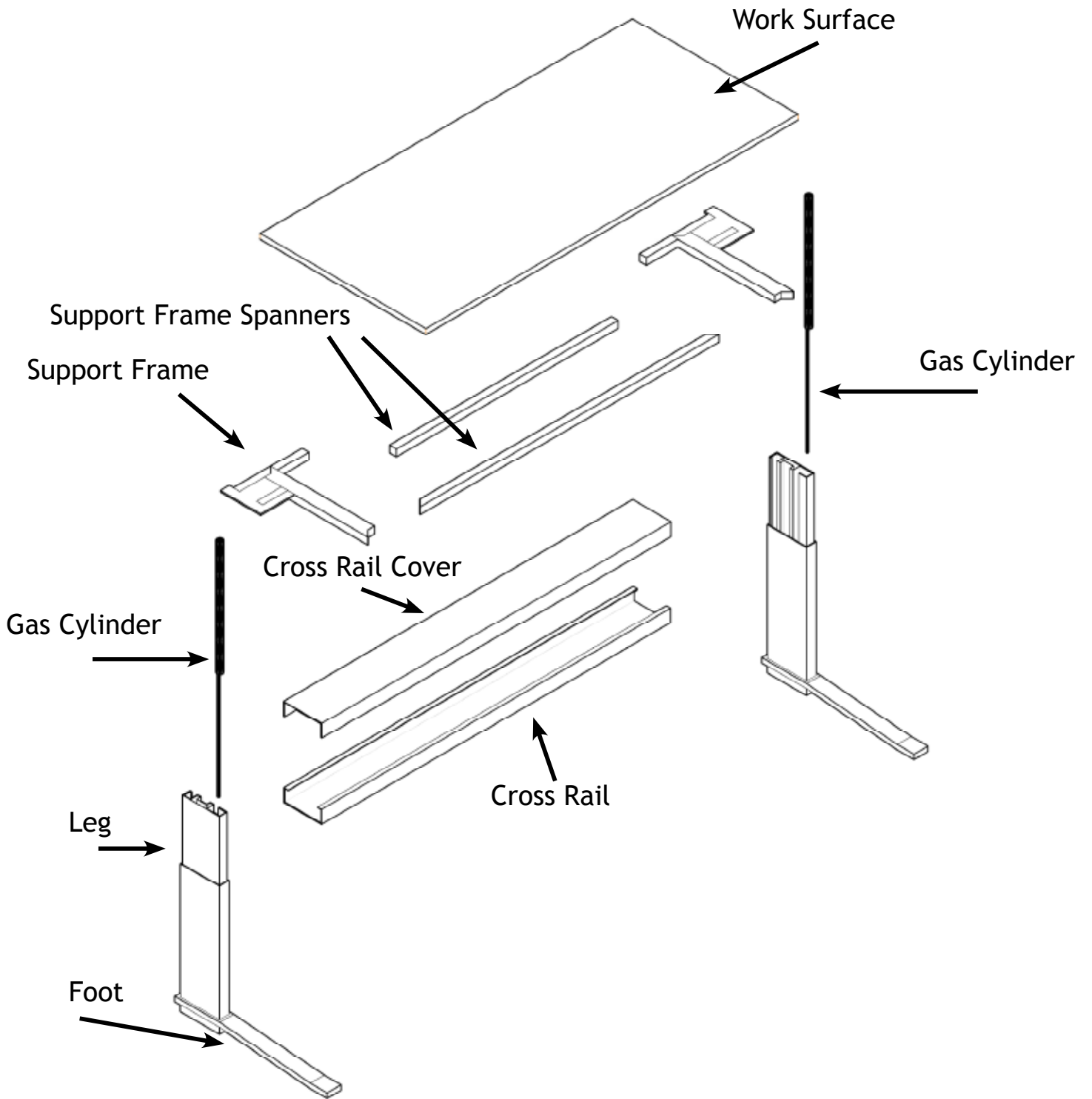

iMove-C Assembly Manual
(Pneumatic Version-H1/H2)

Table of Contents

Exploded Desk Diagram	3	Section 2: Attaching the Desk to the Lowboard/Pedestal	14
Hardware & Tools	4	Attaching Desk to Lowboard-Pedestal	15
Section 1: Basic Assembly of Desk Shipped “KD” (knock down)	5	Section 3: Accessories	17
Unpack and Identify Parts	6	Section 4: Care & Maintenance FAQ & Troubleshooting	19
Assemble Cross Rail to Columns	6	Section 5: Contact Us	22
Connecting Desktop Supports to Columns	8		
Assemble Work Surface Support Frame	9		
Attach Work Surface to Support Frame	10		
Replace Cross Rail Cover and Trim	11		
Attach Hand Lever	12		
Leveling and Calibrating Desk	13		



Tools and Hardware

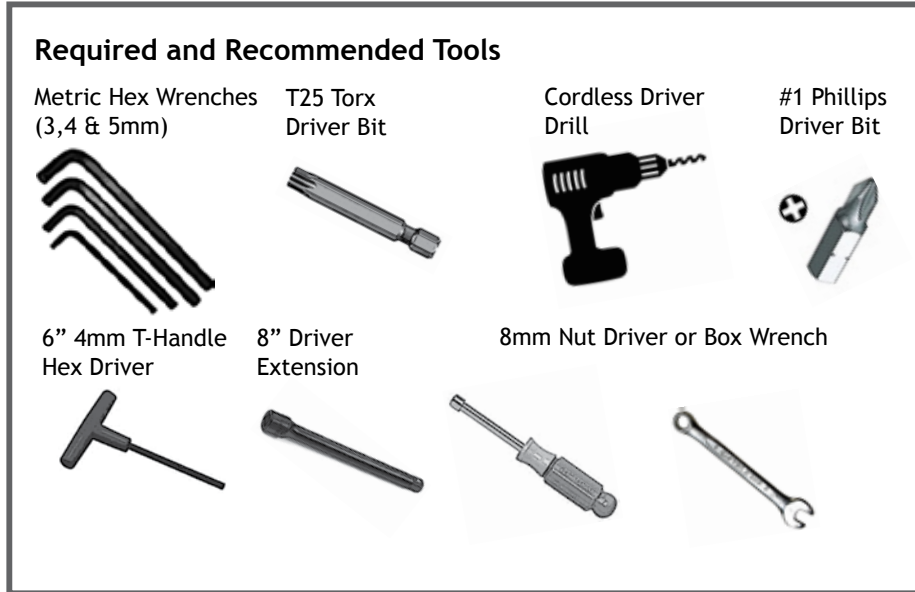

Section 1: Basic Assembly of Desk
Shipped “KD” (knock down)
-Pneumatic Version-
[H1-no calibration H2-weight compensation]

Basic Assembly of Desk Shipped “KD” (knock down)

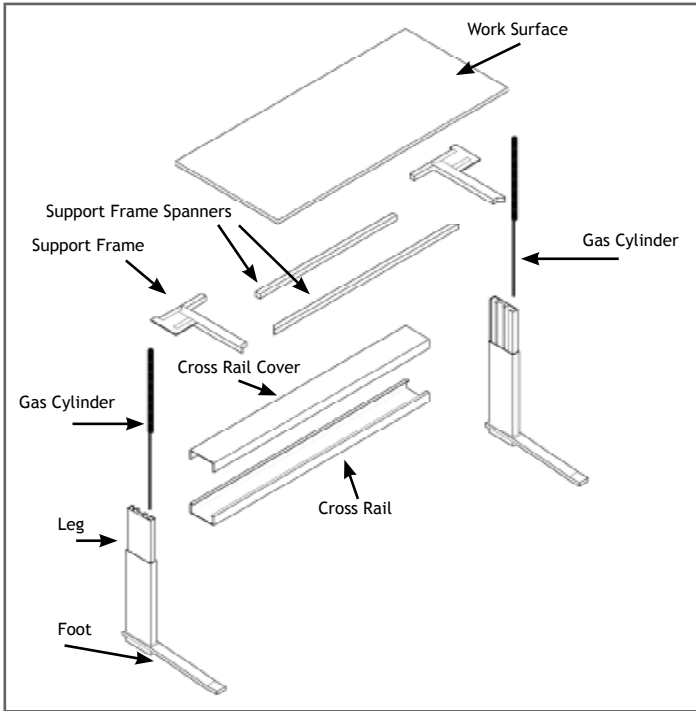

pic.1

1. Identify and uncrate ALL parts (pic.1)

NOTE:

1. Not all desks will require two gas cylinders. The number of gas cylinders will depend on the size and weight of desk top.

2. If user is providing their own custom top, determine the weight of the top and contact eisys to order the appropriate gas cylinders. (This step should have been completed at order entry).



Use caution when working with compressed gas cylinders. An uncontrolled release could cause severe damage and/or personal injury.



pic.2

2. Assembling Cross Rail to Columns (Legs)

- a. Use the 8mm nut driver or socket to remove cross rail cover at indicated positions. (pic.2-3)

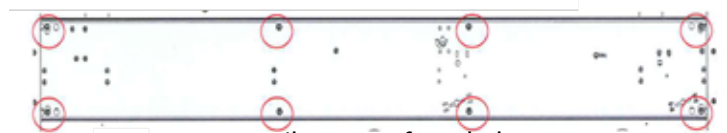

cross rail as seen from below
pic.3



pic.4

- b. After removing cover, note that H1 does not have a torsion spring. (pic.4)

H2 only, carefully examine the large torsion spring to ensure it is in its fully relaxed position (collapsed). (pic.4a)



pic.4a
(H2 only)



WARNING!!! *If torsion spring is in a tight position (expanded) STOP! Go to Section 5 and contact coronaDESKING immediately!*

Basic Assembly of Desk Shipped “KD” (knock down)

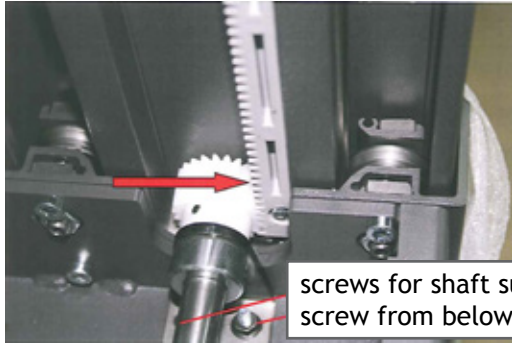

pic.5

2. Assembling Cross Rail to Columns (Legs) (continued)

- c. Using the 3mm & 8mm wrenches, loosen/remove the two drive shaft support bracket bolts at each end of cross rail. (pic.5 & pic.6)

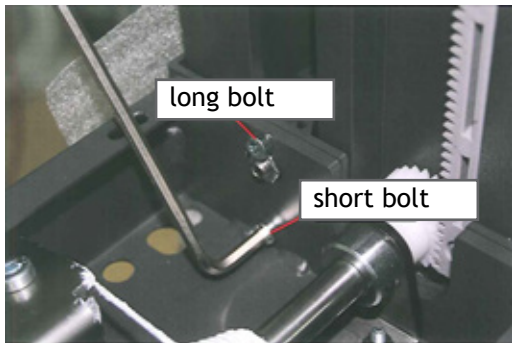

pic.6

- d. With the “inner leg” FULLY extended join the cross rail to the leg and carefully insert the gear into the track. (pic.5) Make sure the inner leg is FULLY extended and the gear is properly engaged with the track.

***TIP:** The screw head at the end of the geared track should be aligned with the approximate center of the drive shaft/gear when the leg is at max height. (pic.7)



pic.7

- e. Once cross rail is secured to legs, make sure the gear is seated with the geared track then tighten shaft support bracket bolts. (pic.8)



pic.8



CRITICAL!!! Make sure the gears in both columns (legs) are aligned at the exact same position in each gear track per above *TIP and picture 7.

Basic Assembly of Desk Shipped “KD” (knock down)

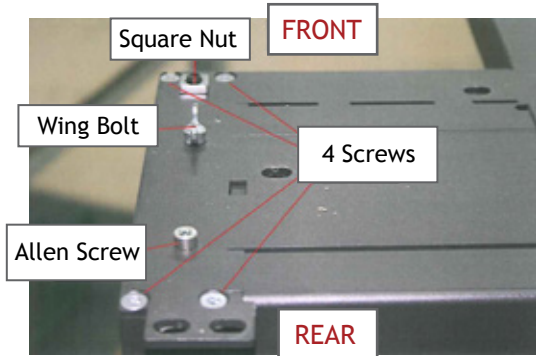

pic.9

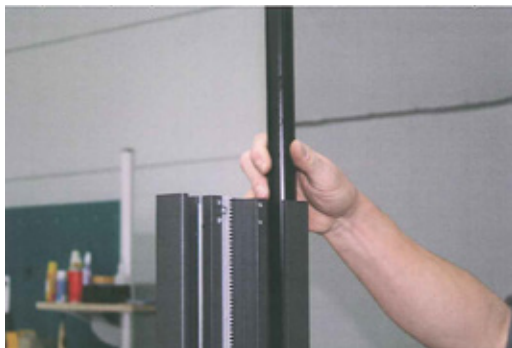

pic.10



pic.10a

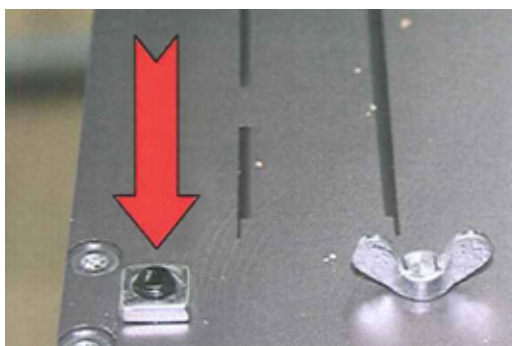

pic.11

3. Connecting Desktop Supports to Columns

a. Use a T25 Driver and 4mm Hex Drive to remove top cover plate from leg assembly. (pic.9)

b. Install gas cylinders as shown (piston down) (pic.10)

Screw the cylinder piston into bottom plate. (hand tight)

REMOVE square nut at the end of the cylinder, (pic 10a)

c. Re-install support plate to column with four torx-screws, each using the outermost holes. (pic.9)

Screw in Allen screw. Screw in wing bolt by hand until hand-tight. Wings must be parallel to outside edge. (pic.11)

Screw square nut carefully on the gas spring. it should be screwed down completely on the cylinder AFTER RE-INSTALLATION of the cover (pic.11)



DO NOT attempt to operate desk once the gas cylinders are installed and before top is attached. The force of the cylinders without the weight of the top could damage the desk mechanism.

Basic Assembly of Desk Shipped “KD” (knock down)



pic.12

4. Assemble Work Surface Support Frame

- a. Install spanner tubes between support plates with the larger diameter access holes facing down before attaching plates to top of legs. (pic 12)
- b. Secure support frame to inside of columns with 4 bolts. (pic 13)



pic.13



WARNING! Examine underside of worktop. Make sure “drillings” match top drawings. Top MUST fit flush on work surface support frame. If accurate proceed to Step 5.

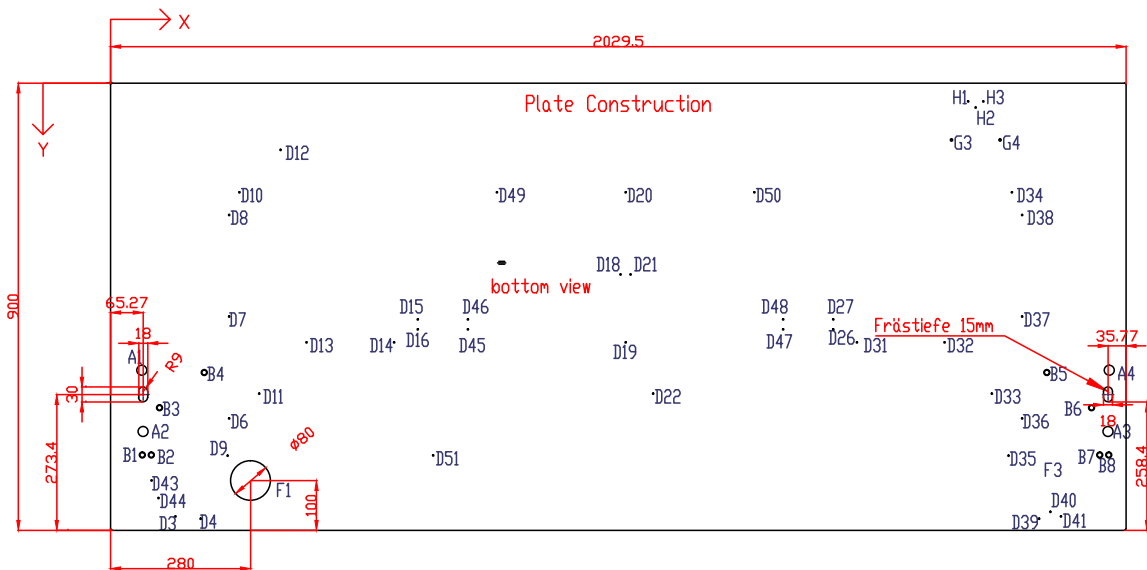

Generic Drilling Diagram
(your diagram may be different)

Basic Assembly of Desk Shipped “KD” (knock down)

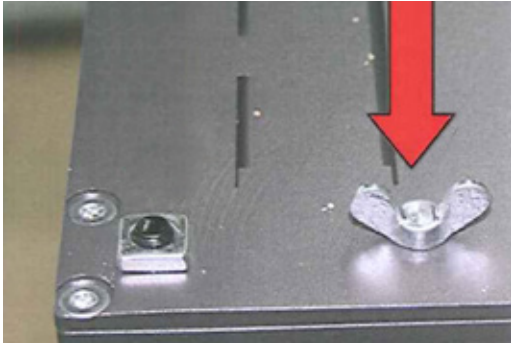

pic.14

5. Attach Work Surface to Support Frame

a. Be sure the wing nut at the top of each leg is parallel with the side of the leg so it will align with the pre-drilled recess in the work surface (pic.14)

b. Place Desktop on floor with drillings visible. Flip Frame upside down and align holes to drillings. (pic.15)



pic.15

c. Align the threaded inserts with holes in the support plates. Use the 8 bolts provided to attach the work surface. (pic.16)



WARNING! The iMove Series uses a variety of top thicknesses. **VERIFY** length of wood screws are appropriate for the thickness of the top prior to fastening

d. Use wood screws to secure the rest of the frame to the top. (pic.17)

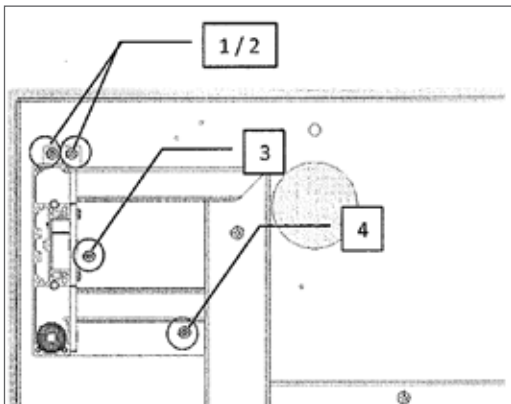

pic.16

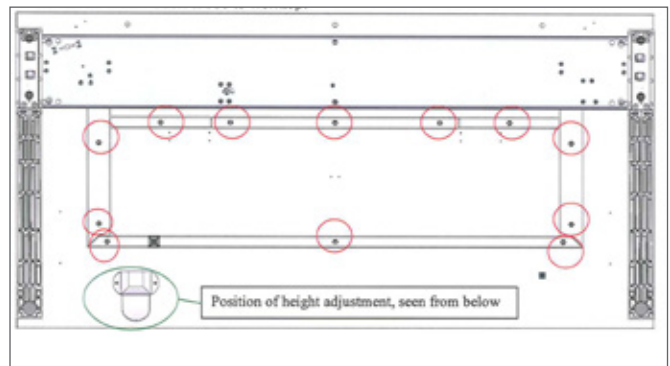

pic.17

Basic Assembly of Desk Shipped “KD” (knock down)



pic.18

6. Replace Cross Rail Cover and Trim (as shown). (pic. 18 & 19)

a. Align cover on top of cross rail

b. Screw cover to cross rail using the 8-8mm hex nuts removed in Step 2. (pic.18 & 19)

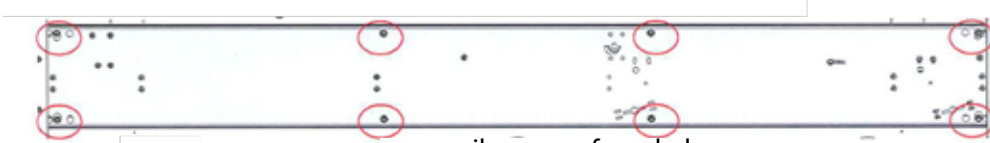

cross rail as seen from below

pic.19

Basic Assembly of Desk Shipped “KD” (knock down)



pic.20

7. Attach Hand Lever

- a. Locate the pre-drilled holes on the underside of the work surface on the user’s right. (pic 20)
- b. Attach Hand Lever accordingly. Cable adjustment may be required for optimal performance.
- c. Attach cable to the underside of the desk as shown on the user’s right. (pic.21)
- d. H2 only—attach weight compensation handle to the underside of the desk top as shown on the user’s left. (pic.22)

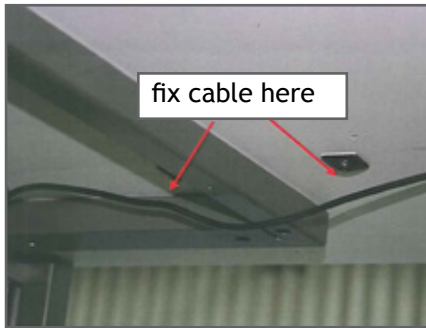

pic.21

NOTE:

If Desk is integrated into a lowboard/pedestal jump to Section 2/page 15, install lowboard-pedestal before moving to Step 8.



pic.22
(H2 only)

Basic Assembly of Desk Shipped “KD” (knock down)

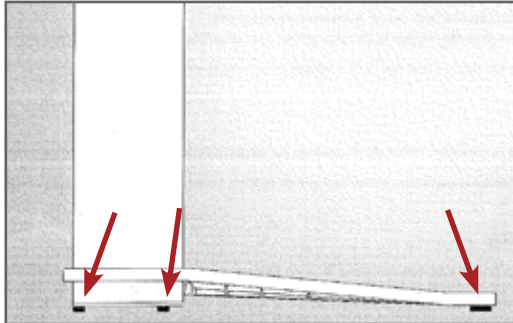

pic.23

8. Leveling and Calibrating Desk

a. Level Desk horizontally using the 3 leveling glides on each leg frame. (pic.23)

b. If Lowboard/Pedestal on one side, level Lowboard to leg frame using glides indicated in pic.23a

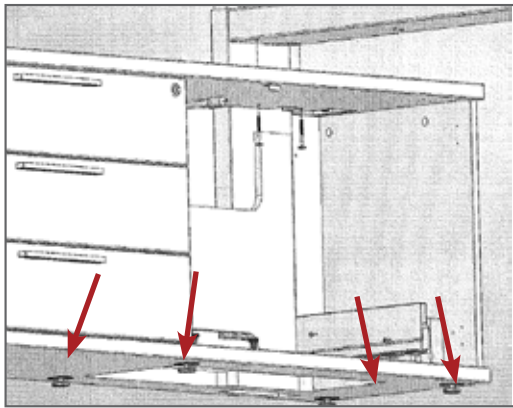

pic.23a

c. Calibrating the Desk.

1. Remove the Red Pan Head Transit Screw located on the under side of the Cross Rail (pic 24)
2. Squeeze hand lever and hold as you move the desk through several up/down cycles.
3. Release hand lever ONLY when Top has come to a full stationary position.



pic.24

NOTE:

If assembled per these instruction, Desk should operate effortlessly through the center section of the height range when desk top is clear (no additional weight).



If desk makes any unusual sounds or does not operate smoothly throughout its FULL Range of motion, STOP IMMEDIATELY, refer to Section 5 and call cornaDESKING at once.

Section 2: Attaching the Desk to the Lowboard/Pedestal

Step by Step Assembly Instructions

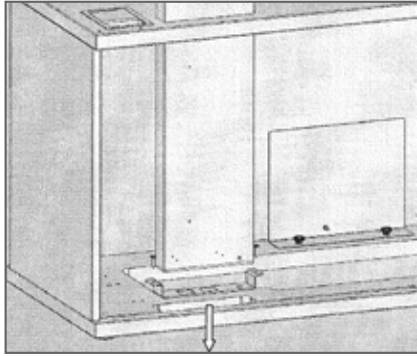

pic.25

9. Attaching Desk to Lowboard/Pedestal

a. Attach the support plate using two Spax Screws (pic.25)

b. Lift the entire desk to provide a straight entry for the leg. Then carefully Insert the table leg into the provided cut-out in the lowboard/ pedestal and seat leg into the recessed support plate. (pic.25 & 26)

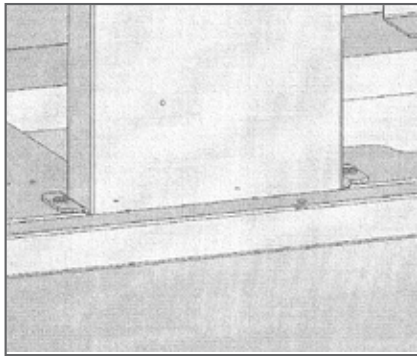

pic.26

c. From inside the lowboard/pedestal bolt the cross rail to the top of the lowboard-pedestal. (pic 27 & 28)

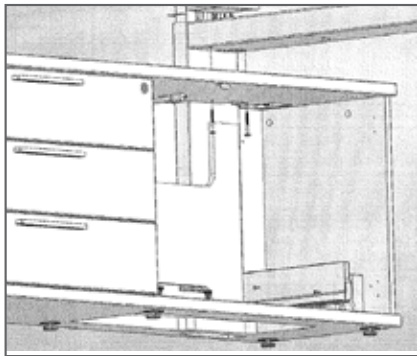

pic.27

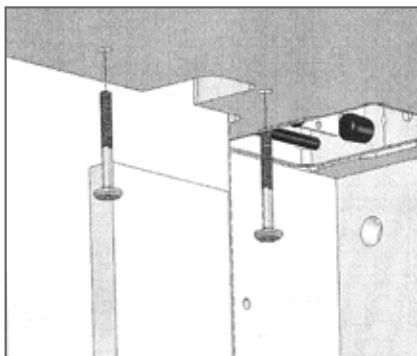

pic.28

Step by Step Assembly Instructions

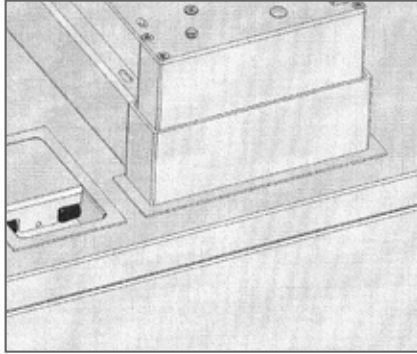

pic.29

9. Attaching Desk to Lowboard/Pedestal (cont.)

d. Install U-Shaped metal trim piece around column (leg). (pic.29)

e. Install Cable Access/Ventilation Plate into corresponding cut-out. (pic.30)

f. Install Cable Chain to underside of Desk Top above the lowboard/pedestal. (pic.31)



pic.30

NOTE:

Position mounting bracket for Cable Chain at 90° angle prior to fastening.

Raise Desk to highest position. Allow length of Cable Chain to enter lowboard/pedestal 2". Remove any excess Cable Chain from interior of cabinet.



pic.31

Section 3: Accessories



Free Standing Cable Chain

See instructions included in the Accessory Box



Cable Bows

See instructions included in the Accessory Box



Desk Top Grommet

If not factory installed, install using templates and instructions provided.



Desk Top Data/Power Module

If not factory installed, install using templates and instructions provided.

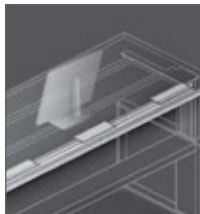

Cable Tray

See instructions included in the Accessory Box



Desk Top Privacy Panel

See instructions included in the Accessory Box



CPU Holder

See instructions included in the CPU Holder Box

Section 4: Care and Maintenance FAQ & Troubleshooting

Care & Maintenance

1. Cleaning—

Soft damp cloth only.
No solvent based or abrasive cleaner.

***TIP:** When cleaning a wood veneer surface, always wipe “with the grain” to avoid creating any visible scratches.

2. Lubrication—

Every desk should be fully lubricated at the factory. Should additional lubrication be required, apply a small amount of lithium grease as needed. Only apply lubricant to “moving” parts within the cross rail. Excess lubricant on exposed surfaces of the desk should be cleaned with warm soapy water and a soft cloth.

FAQ & Troubleshooting

1. How much weight can I put on the top of the desk?

The typical desk is set up to safely handle the weight of the top and any additional weight according to the chart below.

2. Adjustments & Calibration—

If the Hand Lever Cable requires adjustment, tighten and/or loosen bolt/nut at rear of Hand Lever.

Manual Sit-Stand Adjustment

Static *loading max.	265 lbs (120 kg)
movable *load option H2	0-88 lbs (0-40 kg)
movable *load option H1-Z3	44-132 lbs (20-60 kg)
movable *load option H1-Z4	88-176 lbs (40-80 kg)

*load = additional weight equally distributed on the desk top.

3. Use of Weight Compensation Handle-(H2 only)

See user's manual.

Section 5: Contact Information



For additional technical information and help,
contact the following:

Installations-

Greg Hutchens

c 205.902.6164

greg.hutchens@coronagroupinc.com

Customer Service-

Alicia Burrow

p 205.329.7057 (direct)

alicia.burrow@coronagroupinc.com



where custom is standard

205.941.1942

Birmingham, AL

info@coronagroupinc.com

coronagroupinc.com